

Built-in Hob

Integriertes Kochfeld

**Plaque chauffante encastré e placa encastrável
indbygningskogeplade**

MKN 54102

Gebrauchsanleitung

Blomberg

Please read these instructions before installation or using your appliance!

Dear Customer,

By purchasing this product you have chosen an appliance of advanced technology and high quality.

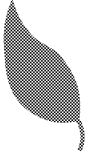

The appliance was produced in modern facilities which meet all environmental standards.

The instructions will help you to operate the appliance quickly and safely.

- Upon delivery, please check that the appliance is not damaged. If you note any transport damage, please contact your point of sale immediately and do not connect and operate the appliance!
- Before you connect and start using the appliance, please read this manual and all enclosed documents. Please note in particular the safety instructions.
- Keep all documents so that you can refer to the information again later on. Please keep your receipt for any repairs which may be required under warranty.
- When you pass on the appliance to another person, please provide all documents with it.



Arçelik A.Ş.
Karaağaç caddesi No:2-6
34445 Sütlüce/Istanbul/TURKEY
Made in TURKEY

Table of Contents

1	General information	4	4	4	4
	Overview				4
	Technical Data				4
2	Safety instructions	5	5	5	5
	Explanation of safety instructions				5
	Basic safety instructions.....				5
	Safety for children.....				6
	Safety when working with electricity .				6
	Intended use.....				6
	Disposal				6
	Packaging material				6
	Old equipment				6
	Future transportation				7
3	Installation	8	8	8	8
	Before installation				8
	Installation and connection.....				8
4	Preparation	11	11	11	11
	Tips for saving energy.....				11
	Initial operation				11
	First cleaning of the appliance				11
5	How to use the hob	12	12	12	12
	General information on cooking.....				12
	How to use hobs.....				12
	Control Elements and Displays.....				13
6	Maintenance and care	21	21	21	21
	General information				21
	How to clean the hob.....				21
7	Troubleshooting	22	22	22	22

1 General information

Overview

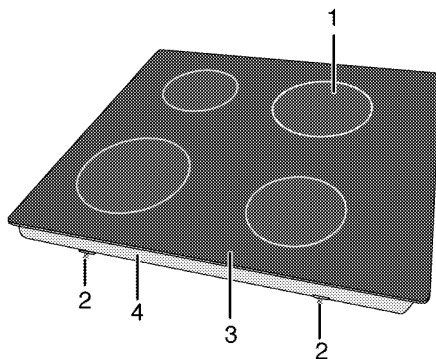

- | | | | |
|---|------------------------------|---|----------------|
| 1 | Single-circuit cooking plate | 3 | Burners' plate |
| 2 | Assembly clamp | 4 | Base cover |

Technical Data

Voltage/frequency	220-240 V~/380-415 V 2N ~ 50 Hz
Total electric consumption	6800 W
Fuse protection	min. 16 A x 3 / 32 A
Cable type / cross section	H05RR-F 5 x 1,5 mm ²
Cable length	max. 2 m
Outer dimensions (height/width/depth)	55 mm/580 mm/510 mm
Installation dimension (width/depth)	560 mm/490 mm
Burners	
Front left	Single-circuit cooking plate
Size	210 mm
Power	2300 W
Rear left	Single-circuit cooking plate
Size	140 mm
Power	1200 W
Rear right	Single-circuit cooking plate
Size	180 mm
Power	1800 W
Front right	Single-circuit cooking plate
Size	160 mm
Power	1500 W

2 Safety instructions

Explanation of safety instructions

The following types of safety instructions and information are used in this manual. They can be distinguished by the symbol and the initial signal word.

 **High risk of personal injury.**
Non-observance may or will cause serious injuries or death.

 **Risk of personal injury.**
Non-observance may or will cause minor or medium injuries.

 **Risk of material damage.**
Non-observance may or will cause damage on the appliance or other objects.

 **Tip for the user.**
Useful information on how to use the appliance. No injury risk information.

Basic safety instructions

- The manufacturer reserves its right to make changes in the technical specifications in order to improve the appliance quality without any prior notice. Figures included in this manual are for schematic purpose only and may not match exactly with your appliance. Values stated on the markings of the appliance or in other printed

documents supplied with the appliance are obtained under laboratory conditions as per relevant standards. These values may vary according to the usage of the appliance and ambient conditions.

- This appliance is not intended for use by persons (including children) with reduced physical, sensory or mental capabilities, or lack of experience and knowledge, unless they have been given supervision or instruction concerning use of appliance by a person responsible for their safety. Children should be supervised to ensure that they do not play with the appliance.
- Never use when judgement or coordination is impaired by the use of alcohol and/or drugs.
- Do not operate the appliance if it is defective or shows any visible damage.
- Do not carry out any repairs or modifications on the appliance. However, you may remedy some malfunctions; see *Troubleshooting*, page 22.
- Be careful when using alcoholic drinks in your dishes. Alcohol evaporates in high temperatures and may catch fire when it comes in contact with hot surfaces.
- Do not heat closed food containers and glass jars. Pressure that may build-up in the jar can cause it to burst.

- Ensure that no flammable materials are adjacent to the appliance as the sides become hot during use.
- Do not leave empty pots or pans on plates that are switched on. They may get damaged.
- Since it may be hot, do not leave plastic or aluminum dishes on the surface of appliance. These kind of dishes should not be used to keep food either.
- Check all controls on the appliance are switched off after use.

 For the warranty to be valid, the appliance must be installed by a qualified person in accordance with current regulations.

Safety for children

- Accessible parts of the appliance will become hot whilst the appliance is in use and until the appliance has cooled, children should be kept away.
- Do not store any items above the appliance that children may reach.
- The packaging materials will be dangerous for children. Keep the packaging materials away from children. Please dispose of all parts of the packaging according to environmental standards.

Safety when working with electricity

- Any work on electric equipment and systems may only be carried out by authorized qualified persons.
- In case of any damage, switch off the appliance and disconnect it

from the mains supply by removing the fuse or switching off the circuit breaker.

- Ensure that the fuse rating is correct.

Intended use

The appliance is designed for domestic use only. Commercial use is not admissible.

This product should not be used for heating purposes.

The manufacturer shall not be liable for any damage caused by improper use or handling errors.

Disposal

Packaging material

-  Risk of suffocation by the packaging materials!
Keep children away from the packaging materials.

The packaging material and transport locks are made from materials that are not harmful to the environment. Please dispose of all parts of the packaging according to environmental standards. This is beneficial to the environment.

Old equipment



This appliance bears the selective sorting symbol for waste electrical and electronic equipment (WEEE). This means that this appliance must be handled pursuant to European Directive 2002/96/EC in order to be recycled or dismantled to minimize its impact on the environment. For further information, please contact your local or regional authorities.

Electronic appliances not included in the selective sorting process are potentially dangerous for the environment and human health due to the presence of hazardous substances.

Future transportation

 Do not place other items on the top of the appliance. The appliance must be transported upright.

Store the appliance's original box and transport the appliance in its original

carton. Follow the guidance marks that are printed on the carton.

 Verify the general appearance of your equipment by identifying possible damage during the transportation.

If you do not have the original carton

Pack the appliance in bubble wrap or thick cardboard and tape it securely in order to prevent damage during transportation.

3 Installation

Before installation

The hob is designed for installation in a commercial worktop. A safety distance must be left between the appliance and the kitchen walls and furniture. See figure (values in mm).

- Remove packaging materials and transport locks.

- Surfaces, synthetic laminates and adhesives used must be heat resistant (100 °C minimum).
- The worktop must be aligned and fixed horizontally.
- Cut aperture for the hob in worktop as per installation dimensions.

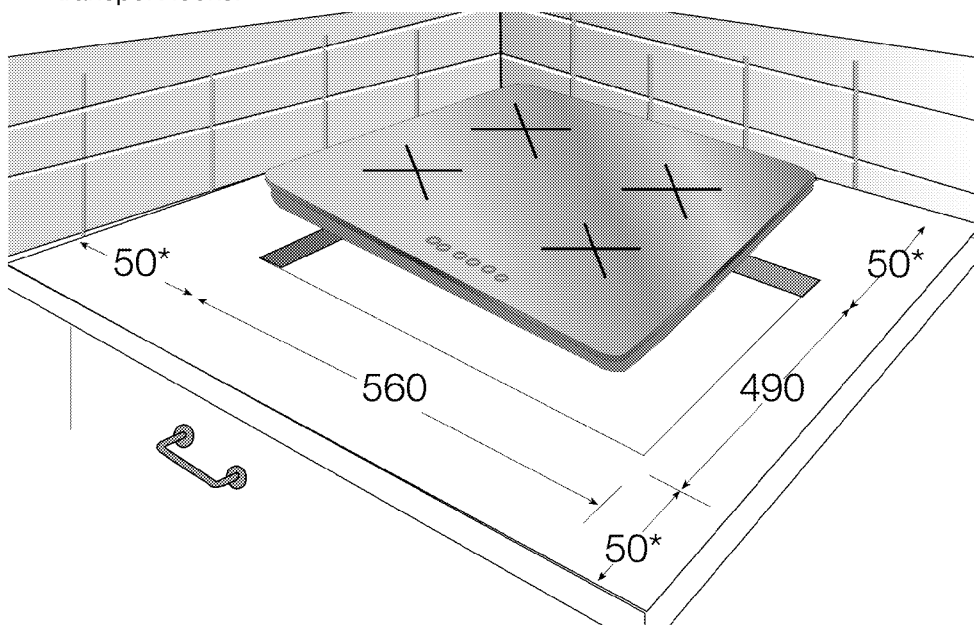

* min.

Installation and connection

- i** Risk of broken glass!
Do not put the ceramic hob down on a corner or edge.
- For installation the appliance must be connected in accordance with all local gas and/or electrical regulations.

Connection to the mains supply

i This appliance must be earthed!

Our company shall not be held responsible for any damage caused by using the appliance without an earthed socket.

⚠ Risk of electric shock, short circuit or fire by unprofessional installation!
The appliance may be connected to the mains supply only by an authorized qualified person and the appliance is only guaranteed after correct installation.

⚠ Risk of electric shock, short circuit or fire by damage of the mains lead!
The mains lead must not be clamped, bent or trapped or come into contact with hot parts of the appliance.
If the mains lead is damaged, it must be replaced by a qualified electrician.

- The mains supply data must correspond to the data specified on the rating plate of the appliance. The rating plate is located at the rear housing of the appliance.
- The appliance mains cable must correspond to the specifications and the power consumption; see *Technical Data, page 4*.

⚠ Risk of electric shock!
Before starting any work on the electrical installation, please disconnect the appliance from the mains supply.

1. If no all-pole separation from the mains supply is possible, a separation unit must be connected with a contact distance of 3 mm min. (fuses, line safety switches, contactors) all poles which should be adjacent to (but not above) the

cooker in accordance with IEE regulations. Failure to observe this instruction may result in operational problems and invalidation of the appliance warranty.

Additional protection by a residual current circuit breaker is recommended.

If a cable without a plug is provided together with your appliance;

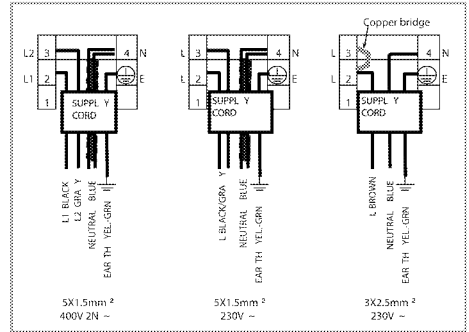

2. **for mono-phase connection**, take care to connect as below:
 - Brown cable = L (Phase)
 - Blue cable = N (Neutral)
 - Green/yellow cable must be connected to ground (E) \equiv line.
3. **for two-phases connection**, take care to connect as below:
 - Brown cable = L1 (Phase 1)
 - Black cable = L2 (Phase 2)
 - Blue cable = N (Neutral)
 - Green/yellow cable must be connected to ground (E) \equiv line.

Installation

1. In hobs whose edges are framed, apply the sealing gasket provided in the package to the edges of base cover of the appliance from below.



2. Place hob into aperture and align it.
3. Connect it to the holes in the lower housing as indicated in the figure.

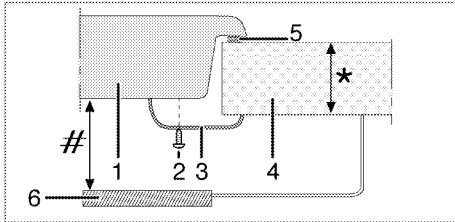

- * min. 20 & max. 40 mm
- # min. 50 mm
- 1 Hob
- 2 Screw
- 3 Fixing clamp
- 4 Worktop
- 5 Sealing gasket
- 6 Dividing shelf

i When installing the hob above a cupboard, a dividing shelf as in the above picture must be installed. If installing above a built-in oven this is not required.

If, for example, due to the fitting of the appliance above a drawer, the underside of the appliance is touchable, it must be covered by a wooden plate.

Bottom view (clamp holes)

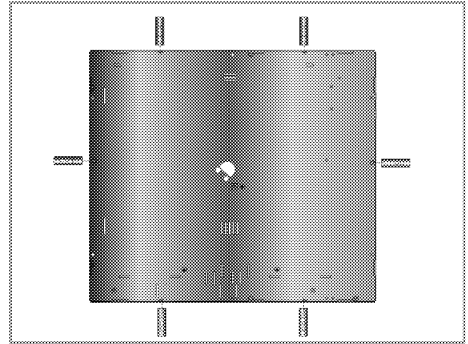

Secure the hob.

i Clamping to different holes is not a good practice in terms of safety since it can damage the gas and electrical system.

Final check

1. Connect the appliance to the mains supply and switch on the mains supply.
2. Check function.

4 Preparation

Tips for saving energy

The following tips will help you to use your appliance in an ecological way and to save energy:

- Use pots/pans with lids for cooking. Without a lid, the energy consumption may be up to four times higher.
- Choose the burner/plate which is suitable to the saucepan base. Always choose the correct size of saucepans for your meals. For larger burners/plates more energy is needed.
- Take care to use flat base saucepans while cooking on electrical cookers. Pots with an even and thick bottom provide better thermal conduction. You can save up to 1/3 of electricity.
- Pots and pans should match the size of plates. The bottom of the pot or pan should not be smaller than the plate.

- Keep plates and pan bottoms clean. Dirt will reduce the heat transmission between plate and pan bottoms.
- In case of longer cooking times, switch off the plate 5 to 10 minutes before the end of the cooking time. When you use the residual heat, you can save up to 20 % of electricity.

Initial operation

First cleaning of the appliance

 The surface may get damaged by some detergents or cleaning materials.

Do not use aggressive detergents, cleaning powder/cream or any sharp objects.

1. Remove all packaging materials.
2. Wipe the surfaces of the appliance with a damp cloth or sponge and dry with a cloth.

5 How to use the hob

General information on cooking

⚠ Risk of fire by overheated oil!
When you heat oil, do not leave it unattended.

Never try to extinguish the fire with water! When oil has caught fire, immediately cover the pot or pan with a lid. Switch off the hob if safe to do so and phone the fire service.

- Ensure handles of pans cannot accidentally be caught or knocked and do not get hot by adjacent heating zones. Avoid pans that are unstable and easily tipped. Pans that are too heavy to move easily when filled can also be a hazard. Only use flat bottomed pots or pans.
- Use pans which have sufficient capacity for the amount of food being cooked so they don't boil over and cause unnecessary cleaning. Do not place lids on the burners. Always position pans centrally over the burners. When transferring pans from one burner to another always lift the pans do not slide them.

Tips for glass ceramic hobs

- The glass ceramic surface is heat-resistant and insensitive to large temperature deviations.
- Do not use the glass ceramic hob for keeping objects or as cutting surface.

- Use pot and pans with ground bottoms. Sharp edges cause scratches on the surface.
- Do not use aluminium pots and pans. Aluminium damages the glass ceramic surface.

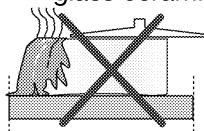

Splashes may damage the ceramic surface and can cause fire.

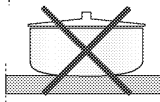

Do not use pots that have concave or convex bottoms.

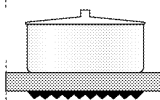

Use pot and pans with smooth bottoms. They ensure a good heat transfer.

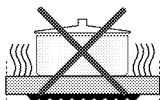

If the pan is too small energy is wasted

How to use hobs

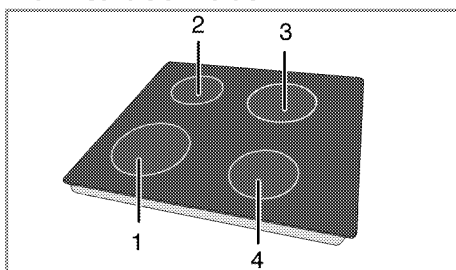

- 1 Single-circuit cooking plate 21-23 cm
 - 2 Single-circuit cooking plate 14-16 cm
 - 3 Single-circuit cooking plate 18-20 cm
 - 4 Single-circuit cooking plate 16-18 cm
- is list of advised diameter of pots to be used on related burners.

-  Broken glass!
Do not let any objects fall onto the hob. Even small objects (e.g. salt shaker) may damage the hob.
Do not use glass ceramic hobs with cracks. Water may enter into the cracks and cause a short circuit.
If the surface is damaged in any way (e. g. visible cracks), switch off the device immediately to reduce the risk of an electric shock.







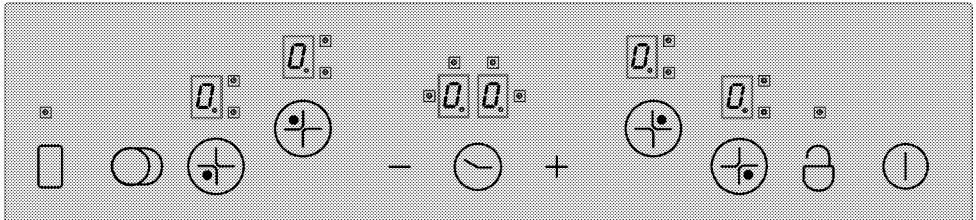



The glass ceramic hob is equipped with an operating lamp and a residual heat indicator.
The residual heat indicator indicates the position of the switched on plate and remains illuminated after switching off. (When the temperature of the plate falls below touchable temperature the indicator light will go off). Weak flicker illumination is not a problem at residual heat indicator light.



-  Quick heating glass-ceramic hobs emit a bright light when they are switched on. Do not stare to bright light.



Control Elements and Displays



Features

-  Main switch - ON/OFF Key
-  Key lock
-  Heat setting/Timer increase
-  Heat setting/Timer decrease
-  ** Dual/triple zone-Selection Key
-  * Activate/deactivate timer
-  ** Activate/deactivate warming zone
-  Hotplate (cooking zone) Selection controls
- 
- 
- 

-  Hotplate display (heat setting 0...9)
-  Dual/Triple zone in operation display via LED (Hotplate display)
-  * Timer display (4 LED assigned for 4 different hotplate)

-  This appliance controls via the touch control unit. If your touch control unit has a timer, each operation is confirmed with an audio signal.
-  Always keep the control panels clean and dry. Moisture and dirt may impair function.

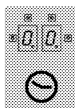

(*) If your hob is equipped with timer.



** If your hob is equipped with these functions

in models with timer.

The graphics and figures are for illustration purposes only. The actual view or functions may differ.

Turn on the hob

Touch the "ⓘ" key in the control panel at least 1 second. The hotplate displays will light up. The hob is ready for use. You can now turn on (select)

different hotplates within next 10 seconds. While operating the main switch "ⓘ", it is not allowed to operate other controls.

All hotplate displays flashes "0." and all related decimal points.

The hob will be set automatically stand by mode if there is no operation within 10 seconds.

If the main switch "ⓘ" is touched more than 2sec, the hob is turned off and is set into the stand-by mode again.

Select Hotplates (Cooking Zone)

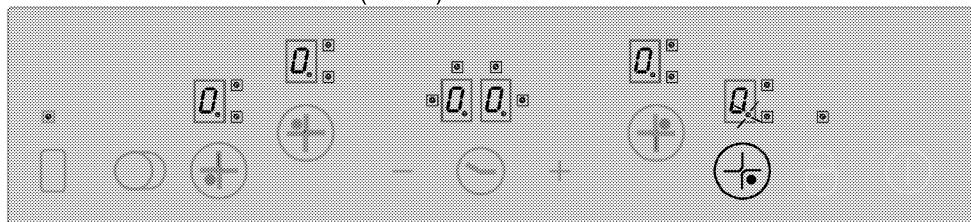

1. Turn on the hob.
2. Touch one of the hotplate selection control of desired hotplate. After selection of the hotplate, the decimal point of the related hotplate display "0." flashes.

The hob will be set automatically stand by mode if there is no operation within 10 seconds.

3. Set the heat level between "1" and "9" or "9" and "1" by touching the "+" or "-" keys.

The "+" or "-" keys are equipped with a repeat function. If you touch one of the key longer time, heat level will continually be increased or reduced at every 0,4 second.

If you begin with "+" key, "1" will appear. If you begin with "-" key, the display will show setting value (e.g.

half second "A" and half second "9"). This means Heat Boost is active now.

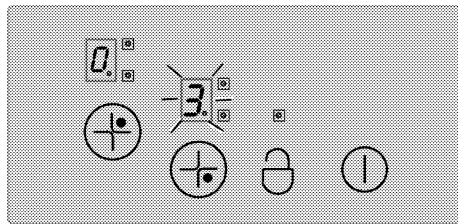

Heat Boost

This function makes cooking easier. If the heat boost is active, than the hotplate will be operated with maximum power for a period of time (see table-1). Heat boost time is depending on selected heat level. This is indicated through a flashing "A" alternating with the heat setting value (e.g. half second "A" and half second "9") in the hotplate display. At the end

of the heat boost time, hob will turn down the heat setting value you selected will be indicated continually. Every hotplate is equipped with heat boost functionality.

Turn On Heat Boost Feature :

1. Turn on the hob.
2. Select desired hotplate by touching hotplate selection keys.
3. Select the hotplate heat settings value "9" using "_" key. After heat setting, "9" and "A" will be indicated alternating. This means heat setting value "9" and heat boost feature is active now.
4. Then set the desired heat setting value at which the cooking will continue at the end of heat boost time, using "_" key within 10 seconds. By touching the "+" or "_" keys of the hotplate, the heat setting between "9" and "1" can be used. (e.g. you set the level 6).
5. The display alternates during heat boost cooking between "A" and "6" (e.g.) At the end of the heat boost time "6" will be indicated continually.

Turn Off Heat Boost Feature :

- The heat boost can be turned off early by touching the "_" key until heat setting "0" appears.
- If heat setting "9" will be chosen as under selection of the heat boost and no low heat setting is chosen, the flashing will be finished after 10 seconds. The heat boost is not longer active.

Turn Off The Hob

If the main switch "ⓘ" is touched more than 2sec, the hob is turned off and is set into the stand-by mode again.

If there is a residual heat available when the hob is turned off, this will be indicated by a steady "H" in the relevant hotplate display.

Turn Off Individual Hotplates :

A selective hotplate can be turned off with 3 different ways:

1. Simultaneous touching of the "+" and "_" keys
2. Reduction of the heat setting to "0" by touching the "_" key
3. Use of timer turn off function for related hotplate. (If timer function is available)

1.Simultaneous operation of the "+" and "_" keys

The desired hotplate must be chosen with the hotplate selection "⊕" key . The decimal point appears in the hotplate display "0.". The "+" and "_" keys must be touched at the same time to turn off the hotplate.

2.Reduction of the heat setting to "0" by operating the "_" key of the desired hotplate

The hotplate can also be turn off by reducing the heat setting to "0".

3.Use of timer turn off function for desired hotplate (If timer function is available)

The timer turns off the linked hotplate when the time has run out. All displays indicates "0" and "00". Dual/Triple zone and timer linked LEDs will be disappear.

Additionally when the time has run out, the buzzer will sound. You have to touch any key on touch control panel to stop the buzzer sound.

Turn On Dual and Triple Zones**

Turn on the dual zone :

The desired hotplate equipped with a dual zone must be selected. The decimal point of the relevant hotplate must be flash.

After setting the heat setting value **1-9**, touch "○" key to activate the dual zone of the hotplate.

At the same time, the related dual zone "8." LED flashes statically. Touching the "○" key for a second time, the status of the dual zone toggles: it changes from dual zone on to dual zone off and back again.

The extension zone can be activated only, after a level between "1";and "9" is set on the basic zone of the hotplate.

Turn on triple zones :

The desired hotplate equipped with a triple zone must be selected. The

decimal point of the relevant hotplate must be flash. After setting the heat setting value **1 -9**, touch "○" key to activate the dual zone of the hotplate. At the same time, the related dual zone "8." LED goes on statically. If you touch "○" key again, The triple zone-LED "8." will be flashed and the triple zone will be energized.

After touching the "○" key once again, the triple zone of the hotplate will be turned off again. Each operation causes a status change of the dual/triple zones following in this manner.

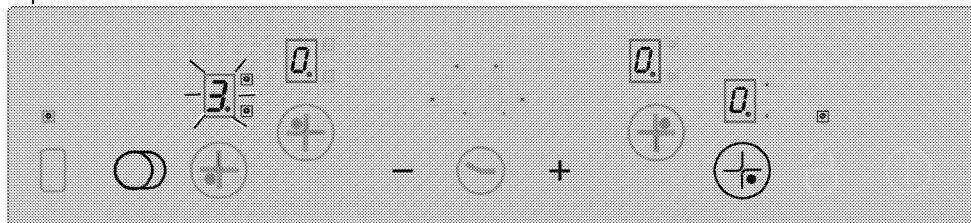

Activating the dual and triple Hotplate by touching "○" Key of the selected hotplate.

Key Lock** (In models with timer)

Touch "○" key more than 2 seconds to lock Touch Control. You will be acknowledged by a audio signal.

Afterwards "○" LED flashes and all hotplates are locked.

The hotplate can only be locked in operating mode. If the hotplate is locked, only the main switch-"○" key can be operated. The "○" LED flashes and indicates a key locked module. If you turn off the hob when keys are locked, key lock will be still active after you restart the hob again. In order to operate the hob in a such condition, key lock should be unlocked.

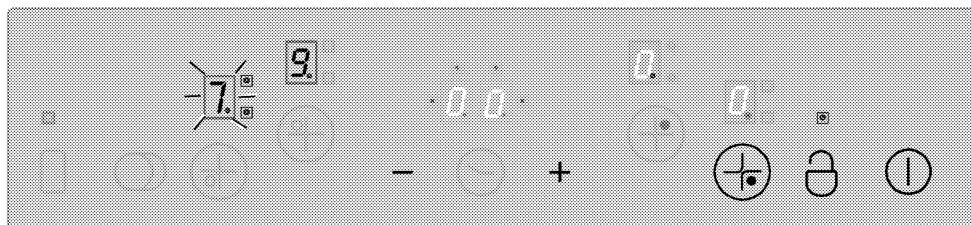

Lock or unlock the Touch control in operation mode by touching the "🔒" key.

If the "🔒" key is touched 2 seconds, the hotplate is unlocked. You will be acknowledged by a audio signal. Afterwards the "🔒" LED disappears, Now, the touch control is unlocked and can be operated in normal order.

Child Lock

To prevent children from turning on the hotplates, you can secure the hob against being turned on inadvertently. Child Lock functionality is foreseen to lock the touch control unit in a complicated Multi-Step process.

How to lock the module:

1. Turn on the hob using main switch "🔌".
2. Simultaneously touching the "+" and "-" for at least 2 sec.
3. Then touch again "+" key.

» Child lock function will be activated and all hotplate displays will indicate "🔒" symbol.

Cancel Child Lock:

The same way the Child lock is activated, it can also get for deactivating.

1. Turn on the hob using main switch "🔌".
2. Simultaneously touching the "+" and "-" keys for at least 2 sec.
3. Then touch again "-" key.

» All hotplate display is indicated "🔒" during period of unlocking. "🔒" will be disappear immediately after successful unlocking.

Timer Function*

This feature facilitates the cooking for you. You do not need to be permanently present during the cooking procedure ; the hotplate is automatically turned off at the selected time.

The timer provides following features: Touch control can run max. 4 hotplate assigned timers and 1 egg timer simultaneously. All timers can be used only in operation mode.

Egg timer:

The egg timer is independent of any hotplate. So it doesn't matter whether a hotplate is selected or not.

1. Start to activation of egg timer by touching "🕒" key. The timer display will indicate "00" and a dot in the right bottom side "🕒". The egg timer is active now.
2. Then set the desired time value by touching "+" and "-" keys.
3. After setting the, time the timer starts to countdown.

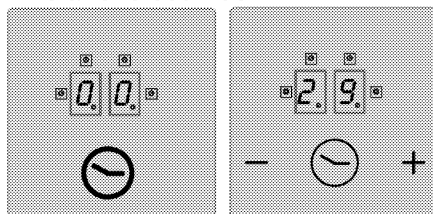

» When the time has run out, the buzzer will sound. You have to touch any key on touch control panel to stop the buzzer sound.

Hotplate timer:

Hotplate timers can be set only for activated hotplate.

1. Firstly turn on the hob and activate desired hotplate, (hotplate level must be set to **1 -9** before)
2. Start to activation of hotplate timer by touching "⊖" key same as with egg timer. The timer display will indicate "00" and a dot in the right bottom side "⊖". The egg timer is active now.
3. You have to touch "⊖" key second time to activate the hotplate timer. Now the timer can be assigned.
4. Set the desired time value with "+" and "-" keys.

To set additional hotplate timers :

1. Touch "⊖" key again after activating the first hotplate timer. The control rotates clockwise to the next active hotplate assigned to a timer. The assignment recommendation is indicated by the flashing "⊖" led.
2. Set the desired time value with "+" and "-" keys.
3. The running timer of the first set hotplate timer is indicated by the statically lighting "⊖" LED.

- Touching the "⊖" key once again further timers can be assigned to other activated hotplates.
- The timer display will change to time that will end first after 10 sec.
- The statically on LEDs "⊖" on timer display identify us the running timers.
- By toggling the "⊖" key you can display the timer values for the hotplate timers and the egg timer. The assignment is always indicated by the flashing Front left led "⊖".
If no led flashes, the Egg timer value is shown in the timer display.

Cancel Timers:

Firstly you have to select the timer by toggling the "⊖" key until it is displayed. The value can be canceled then in 2 different ways:

- decrement by touching the "-" until "00" appears on the timer display.
- touch the "+" and "-" key simultaneously for half second until "00" is shown in Timer display.

When the time has run out, the buzzer will sound. You have to touch any key on touch control panel to stop the buzzer sound.

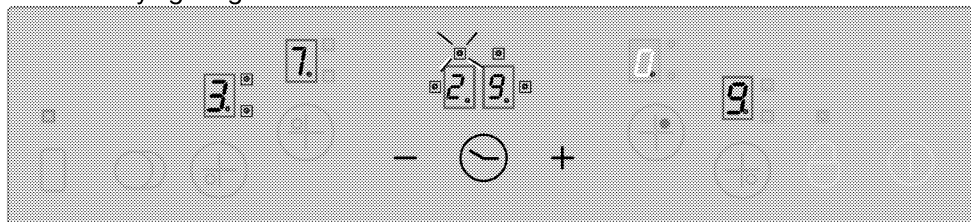

Display remaining value of hotplate timer 3 (indicator led flashing) in Timer

Display (Indicators leds are on indicate

running timers for hotplate 1 and 4, actually not displayed in timer display)

Warming plate function (if available)

Warming Plate functionality for a warming zone offers an means an additional heat level between 0 and 1 keeping the food warm. You can activate Warming Plate functionality by touching the "0" key .

Then LED "0" will flash. Touch "0" again to deactivate warming zone.

Operating time limitations

The hob control has a limitation of the operating time. If one or more hotplates are inadvertently not switched off, hotplate will be automatically deactivated after a

Table -1: Heat setting parameters, Cycle Time 47,0 s

Heat setting	OFF- Time period in s	ON- Time period in s	Operating time limitation in h	Heat boost duration in s
0	0	0	0	-
U	45,9	1,1	6	-
1	45,6	1,4	6	60
2	43,6	3,4	6	180
3	41,3	5,7	5	288
4	38,4	8,6	5	390
5	35,9	11,1	4	510
6	33,1	13,9	1,5	150
7	26,2	20,8	1,5	210
8	19,2	27,8	1,5	270
9	0	47,0	1,5	-

Residual Heat Functions

An "H" (residual heat) lights up on the hotplate displays of a deactivated hotplate or hob if a surface temperature of over 60°C was determined for the hob. A "0" will light up on the display when the residual heat falls down from 60°C.

After an interruption of the supply voltage occurred, that the residual heat display flashes, if the corresponding

certain amount of time, (see table-1 below) The limit of the operating time depends of the selected heat setting. If a timer was associated with the hotplate than a "00" will be displayed on the timer display for 10 seconds.(after 10 seconds residual heat indicator will light).

Afterwards the timer display switches off.

After an automatic switch off of the hotplate, as described above, the hotplate is re-operable again and the maximum operating time for this heat setting is applied.

hotplate had a residual heat of greater than 60 °C before the power interruption occurred. The display will flash until the max. residual heat time has expired or the hotplate will be selected and activated.

Sensor Calibration and Error messages

The hob control performs an automatic calibration in reference to the sensor-, glass- and ambient conditions after the main voltage is applied. No objects are

allowed to cover the glass area of the sensor during the calibration. In addition, the hob control cannot be exposed to strong illumination, like sunlight, strong halogen lights, etc.

Table-2: Error codes and source of errors

Error reason	Display
Ambient light too high	F1
Strong pulsating light (fluorescent tube)	F2
Sensor covered with a bright object	F3
Strongly fluctuating ambient light	F4

Application Example:

The calibration performs without any problems if the following illumination is present:

Illumination through a light bulb without reflector (100W, opal) in a distance of 70 cm above the glass ceramic hob. After a successful calibration the function of the hob is also guaranteed even with strong illumination, for example with halogen spot with reflector (50W).

In case of an error, the calibration is repeated until the ambient conditions allow a successful calibration. The operation of the hob control is only possible, if the calibration of all sensors were successfully completed.

You must remove all objects on the hob during calibration process. Furthermore the ambient light should not be too high during the calibration. In case of the message F2, F3 or F4 the user should switch off all ambient light sources or cover the window for the time of the calibration process after the first connection to the power line. After successful finished calibration process the control tolerates a very high rate of ambient light.



During the operation of the hob control it is continuously adopting and recalibrating towards the change in the ambient conditions.

 The touch control has a sensor which protects against overheating. When responding to this sensor, the relevant burner will be deactivated. For information on explanations or error messages, please see chart.

In the event of the non-stop activation of a button (longer than 10 seconds), the entire control system will be deactivated and a permanent signal will sound.

6 Maintenance and care

General information

-  Risk of electric shock!
Switch off the electricity before cleaning appliance to avoid an electric shock.
-  Hot surfaces may cause burns!
Allow the appliance to cool down before you clean it.
-  The surface may get damaged by some detergents or cleaning materials.
Do not use aggressive detergents, cleaning powder/cream or any sharp objects.

Clean the appliance thoroughly after each use; in this way it will be possible to remove cooking residues more easily, thus avoiding these from burning the next time the appliance is used.

No special cleaning agents are required for cleaning the appliance. It is recommended to use warm water with washing liquid, a soft cloth or sponge and use a dry cloth for drying.

Do not use any abrasive cleaning materials!

-  Do not use steam cleaners for cleaning.

How to clean the hob

Ceramic hobs

Always rinse off fully with a clean cloth wrung out in clean water (as residue could damage the ceramic glass surface next time the hob is used).

In no case should crusts be scratched off with serrated edge knives, steel wool or the like.

Remove calcium stains (yellow staining) with small amounts of decalcifying agents such as Durgol, vinegar or lemon juice.

Apply agent with a sponge and, in the event of heavier soiling, let it work in for a longer period of time. Afterwards, wash offhob with water.

-  Sugar-based food such as custard and syrup should immediately be scraped off without waiting for the surface to cool down. Otherwise the hob may be permanently damaged.

Glass ceramic hob cleaner

Please remove spilled food leftovers and tenacious soil with a special scraper designed for glass-ceramic hobs.

-  Risk of injury!
Never leave hob scrapers within children's reach. Store such articles at a safe place where children cannot reach them: Hob scrapers are razor-sharp.

Hold the scraper at a low angle in order to avoid scratches.

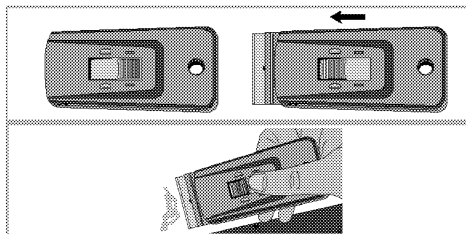

7 Troubleshooting

-  Risk of electric shock, short circuit or fire by unprofessional repairs!
Repairs on the appliance must be carried out by an approved service centre.

Normal operating conditions

- Smoke and smell may emit for a couple of hours during the first operation.
- When the metal parts are heated, they may expand and cause noise.

Before you call the service, please check the following points.

Electrical equipment

Malfunction/problem	Possible cause	Advice/remedy
The appliance does not work.	The mains fuse is defective or has tripped.	Check fuses in the fuse box. If necessary, replace or reset them.

If the problem has not been solved:

1. Separate unit from the mains supply (deactivate or unscrew fuse).
2. Call the after-sales service of your store reseller.

-  Do not attempt to repair the appliance yourself. There are no customer service items inside the appliance.